

Series **STH**

---

UNIVERSAL TORQUE SENSORS

# Reference Guide

**MARK - 10**®

## GENERAL

Carefully remove the sensor from its packaging and inspect for any damage.

Each chuck and bit holder is interchangeable and easily mounted onto the sensor. Align the torque pin on the sensor with the hole on the attachment and insert the guide pin into the sensor. Lightly tighten the knurled ring.

Series STH torque sensors work in conjunction with the BGI force/torque indicator for instantaneous, average, and peak torque measurements. Simply plug the 15-pin connector into the external sensor connector on the indicator.

Please note that all calibration data and menu selections programmed and saved during setup with the BGI are saved within the sensor. While this allows for interchangeability, each sensor must be programmed separately.

The sensor can be used as a hand tool or mounted in a fixture (not included).

In order to extend the life of your torque sensor, avoid repetitive shock and impact loads.

## DIMENSIONS

in [mm]

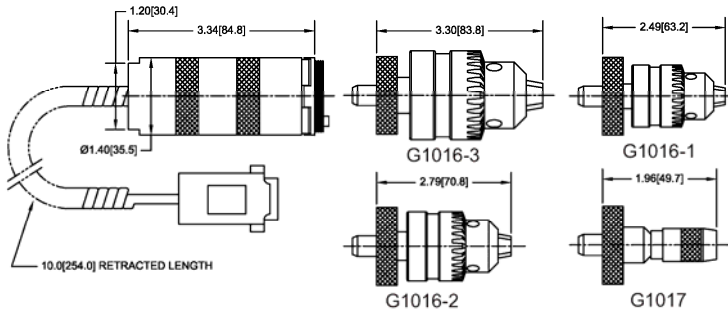

## SPECIFICATIONS

<i>Model</i>	<i>Capacity x Resolution</i>	<i>Safe Overload % of Capacity</i>
STH10Z	10 x 0.01 ozin, 7 x 0.005 kgFmm, 7 x 0.005 Ncm	300
STH20Z	20 x 0.02 ozin, 14 x 0.01 kgFmm, 14 x 0.01 Ncm	
STH50Z	50 x 0.05 ozin, 36 x 0.05 kgFmm, 35 x 0.05 Ncm	
STH12	12 x 0.01 lbin, 140 x 0.01 kgFmm, 135 x 0.01 Ncm	200
STH50	50 x 0.05 lbin, 580 x 0.5 kgFmm, 570 x 0.5 Ncm	
STH100	100 x 0.1 lbin, 1150 x 1 kgFmm, 1150 x 1 Ncm	150

<i>Grip</i>	<i>Sample Diameter Range</i>
G1016-1	0.028 - 0.250 [0.7-6.4]
G1016-2	0.062 - 0.375 [1.6-9.5]
G1016-3	0.078 - 0.500 [2.0-12.7]
G1017	1/4" hex

Accuracy:  $\pm 0.2\%$  FS + BGI  
 Operating Conditions:  
 Temperature: 40°F - 110°F [5°C - 45°C]  
 Humidity: 96% max. (no condensation)

## WARRANTY

Mark-10 Corporation expressly warrants to its buyer for three (3) years from the date of delivery that the goods sold are free from defects in workmanship and materials. Mark-10 Corporation will, at its option, repair or replace or refund the purchase price of goods found to be defective. This remedy shall be the buyer's sole and exclusive remedy. Any modification, abuse, exposure to corrosive environment or use other than intended will void this warranty. This warranty is in lieu of all other warranties, including implied warranties of merchantability and fitness for an intended purpose. In no event shall Mark-10 Corporation be liable for any incidental and consequential damages in connection with goods sold or any part thereof.

# OTHER MARK-10 PRODUCTS

A full line of force and torque measurement products and related items, including force gauges, torque gauges, force and torque test stands, sensors, grips, software, and more.



**MARK-10**

*We make a measurable difference in force and torque measurement*

**Mark-10 Corporation**

11 Dixon Avenue  
Copiague, NY 11726  
888-MARK-TEN  
Tel: 631-842-9200  
Fax: 631-842-9201

Internet: [www.mark-10.com.cn](http://www.mark-10.com.cn)

